



INTERNATIONAL TELECOMMUNICATION UNION

ITU-T

TELECOMMUNICATION
STANDARDIZATION SECTOR
OF ITU

G.983.2

Amendment 2
(01/2005)

SERIES G: TRANSMISSION SYSTEMS AND MEDIA,
DIGITAL SYSTEMS AND NETWORKS

Digital sections and digital line system – Optical line
systems for local and access networks

ONT management and control interface
specification for B-PON

Amendment 2

CAUTION !

PREPUBLISHED RECOMMENDATION

This prepublication is an unedited version of a recently approved Recommendation. It will be replaced by the published version after editing. Therefore, there will be differences between this prepublication and the published version.

FOREWORD

The International Telecommunication Union (ITU) is the United Nations specialized agency in the field of telecommunications. The ITU Telecommunication Standardization Sector (ITU-T) is a permanent organ of ITU. ITU-T is responsible for studying technical, operating and tariff questions and issuing Recommendations on them with a view to standardizing telecommunications on a worldwide basis.

The World Telecommunication Standardization Assembly (WTSA), which meets every four years, establishes the topics for study by the ITU-T study groups which, in turn, produce Recommendations on these topics.

The approval of ITU-T Recommendations is covered by the procedure laid down in WTSA Resolution 1.

In some areas of information technology which fall within ITU-T's purview, the necessary standards are prepared on a collaborative basis with ISO and IEC.

NOTE

In this Recommendation, the expression "Administration" is used for conciseness to indicate both a telecommunication administration and a recognized operating agency.

Compliance with this Recommendation is voluntary. However, the Recommendation may contain certain mandatory provisions (to ensure e.g. interoperability or applicability) and compliance with the Recommendation is achieved when all of these mandatory provisions are met. The words "shall" or some other obligatory language such as "must" and the negative equivalents are used to express requirements. The use of such words does not suggest that compliance with the Recommendation is required of any party.

INTELLECTUAL PROPERTY RIGHTS

ITU draws attention to the possibility that the practice or implementation of this Recommendation may involve the use of a claimed Intellectual Property Right. ITU takes no position concerning the evidence, validity or applicability of claimed Intellectual Property Rights, whether asserted by ITU members or others outside of the Recommendation development process.

As of the date of approval of this Recommendation, ITU [had/had not] received notice of intellectual property, protected by patents, which may be required to implement this Recommendation. However, implementors are cautioned that this may not represent the latest information and are therefore strongly urged to consult the TSB patent database.

© ITU 2005

All rights reserved. No part of this publication may be reproduced, by any means whatsoever, without the prior written permission of ITU.

Amendment 2 to ITU-T Recommendation G.983.2

ONT management and control interface specification for B-PON

Summary

This amendment provides additional (optional) features to G.983.2 (2002). It defines the method for providing transport and management of the Video Return Path function for systems that implement the G.983.1 and G.983.3 B-PON transport system and G.983.2 ONT Management and Control Interface (OMCI). The Video Return Path function constitutes the support of certain elements described in SCTE 55-1 [1] and SCTE 55-2 [2], which allow the control of interactive video services through the use of set top boxes.

1 Scope

This amendment describes the Video Return Path function in B-PON systems.

The normative parts of the document details an ONT integrated VRP solution to support an RF video return path and has two modes of support for the RF return path. These two modes of RF return path support are 1) SCTE-55-1, and 2) SCTE-55-2.

The modifications to the main body of G.983.2 define the OMCI specifications related to support for ONTs with Video Return Path service.

The Annex A addition to G.983.2 defines the transport methods required to support the video return path function. This includes providing a brief description of the relevant aspects of the two return path specifications supported (SCTE 55-1 and 55-2). It also includes the formatting for carriage of the data over the B-PON data path. This material is placed in Annex A, to facilitate the section numbering requirements for the OMCI part of the document; however, it is also normative and is an integral part of the amended recommendation.

The Appendix VII addition to G.983.2 presents three transparent ways to support the video return channel over a B-PON or other access system. The transparent aspect of the video return path is given only for information since it does not impact B-PON standardisation.

2 References

Add the following references:

- [1] SCTE 55-1 (2002), *Digital Broadband Delivery System: Out Of Band Transport Part 1: Mode A*.
- [2] SCTE 55-2 (2002), *Digital Broadband Delivery System: Out Of Band Transport Part 2: Mode B*.

3 Abbreviations

Add the following abbreviations:

BRAS	Broadband Remote Access Server
FEC	Forward Error Correction
HE	Head End
LAN	Local Area Network

MAC	Media Access Control
QPSK	Quadrature Phase Shift Keying
RF	Radio Frequency
STB	Set Top Box
VRP	Video Return Path

4 Performance management

Add the following performance management-related managed entities to the list given in clause 5.3/G.983.2.

- o) Video Return Path Statistics

5 Managed entities associated with Video Return Path Service

Add the managed entities in Table 1/G.983.2a2 to the list given in clause 6.1/G.983.2.

Table 1/G.983.2a2 Additional managed entities in the OMCI

Managed Entity	Required/Optional	Description
Video Return Path Service Profile	CR	Used for Video Return Path service supported by the ONT
Video Return Path Statistics	O	Used for Video Return Path service supported by the ONT

5.1.2 Managed Entity relation diagram for Video Return Path service

Add the following text and figure to section 6.2:

The relationships between the managed entities required for supporting VRP service are indicated in Figure 1/G.983.2a2. Note that the VRP Service Profile and VRP Statistics MEs are both single-instance-only MEs. This is identical to the treatment of the PPTP Video ANI ME. As such, the relationships between all the Video MEs are implicit, and explicit pointers are not provided. The VRP service profile ME is pointed to by the Interworking VCC TP to designate which VCC TP is used for adaptation of the reverse path data into ATM. That VCC TP would point to a LAN/AAL5 profile, and other MEs as usual for AAL5 connectivity service.

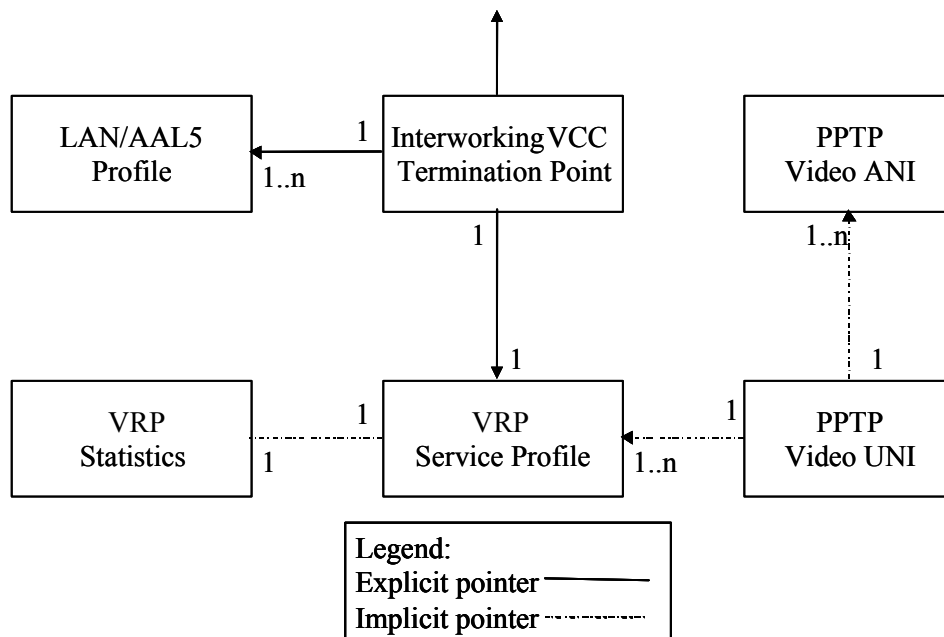

Figure 1/G.983.2a2 – Managed Entity relation diagram for Video Return Path service support

6 Modified Managed Entities

6.1 Interworking VCC Termination Point

In the description of the Interworking Termination Point pointer attribute of the Interworking VCC Termination Point managed entity given in clause 7.3.7/G.983.2 Revised, modify the following attributes:

- Interworking Option:** This attribute identifies the type of non-ATM function that is being interworked; the option can be CES (0x00), MAC Bridge LAN (0x01), Voice (0x02), IP Router (0x03), or Video Return Path (0x04) service. (R, Set-by-create) (mandatory) (1 byte)
- Service Profile Pointer:** This attribute provides the service profile type and a pointer to the instance of a service profile, such as the CES Service Profile_{B-PON} (if the interworking option = 0x00), MAC Bridge Service Profile (if the interworking option = 0x01), Voice Service Profile AAL (if the interworking option = 0x02), IP Router Service Profile (if the interworking option = 0x03), or VRP Service Profile (if the interworking option = 0x04). (R, Set-by-create) (mandatory) (2 bytes)
- AAL Profile Pointer:** This attribute provides the AAL profile type and a pointer to an instance of AAL Profile such as AAL1 Profile_{B-PON} if the interworking option = 0x00, AAL1 Profile_{B-PON} or AAL2 Profile_{B-PON} if the interworking option = 0x02, or AAL5 Profile_{B-PON} if the interworking option = 0x01, 0x03, or 0x04 mode 1. If the interworking option is 0x04 mode 2, then this pointer is not used. (R, Set-by-create) (mandatory) (2 bytes)

7 New Managed Entities for Video Return Path management

The managed entities defined in this section are based on the video return out-of-band interfaces defined in SCTE 55-1 and SCTE 55-2. The assumed ONU architecture is that the video return path function would be shared over all UNIs; that is, that the VRP assumes the role of a service function.

7.1 Video Return Path Service Profile

Add the following text to section 7.3.

Relationships

One instance of this managed entity may exist for each ONU. It is created automatically by the ONU on startup, if the ONU implements this service.

Attributes

- ManagedEntityId:** This attribute provides a unique number for the instance of this managed entity. This 2-byte number always has the value 0x00. (R) (mandatory) (2 bytes)
- AdministrativeState:** This attribute is used to activate (unlock: value 0x00) and deactivate (lock: value 0x01) the functions performed by instances of this managed entity. Selection of a default value for this attribute is outside the scope of this document as it is normally handled through supplier-operator negotiations. (R, W) (mandatory) (1 byte)
- Operational State:** This attribute indicates whether or not this managed entity is capable of performing its task. The operational state reflects the perceived ability to receive or to generate a valid signal. Valid values are enabled (0x00) and disabled (0x01). (R) (optional) (1 byte)
- ARC:** This attribute is used to control alarm reporting from this managed entity. Valid values are “off” (alarm reporting allowed immediately, value 0x00) and “on” (alarm reporting inhibited, value 0x01). Upon initial installation and provisioning of the ONT, this attribute may be set to “on” or “off” for the time interval specified by “ARCInterval.” Similarly, this attribute may be set to “off”. If the attribute is set to “on”, then alarm reporting is inhibited until this managed entity detects a valid signal for the time interval specified by “ARCInterval.” (R, W) (optional) (1 byte)
- ARCInterval:** This attribute provides a provisionable length of time. Units are given in minutes (R, W) (optional) (1 byte)

VRP Mode	<p>This attribute specifies which format is being used for the VRP. These are defined by code-points:</p> <p>0: Mode 1, SCTE 55-1 shall be used (256 kb/s data rate, 62 byte PDUs, preceded by the unique word 0xCC CC CC 0). (mandatory)</p> <p>1: Mode 2, SCTE 55-2 shall be used (256 kb/s data rate, 59 byte PDUs, preceded by the unique word 0xCC CC CC 0D). (optional)</p> <p>2: Mode 2, SCTE 55-2 shall be used (1.544 Mb/s data rate, 59 byte PDUs, preceded by the unique word 0xCC CC CC 0D). (mandatory)</p> <p>3: Mode 2, SCTE 55-2 should be used (3.088 Mb/s data rate, 59 byte PDUs, preceded by the unique word 0xCC CC CC 0D). (optional)</p> <p>4-255: Reserved.</p> <p>(R, W) (1 byte)</p>
VRP Frequency lower bound	<p>This attribute reports the ONU VRP tuning range lower bound, in units of Hertz. (R) (mandatory) (4 bytes)</p>
VRP Frequency upper bound	<p>This attribute reports the ONU VRP tuning range upper bound, in units of Hertz. (R) (mandatory) (4 bytes)</p>
VRP Frequency used	<p>This attribute reports the ONU VRP tuner frequency currently in use, in units of Hertz. (R, W) (mandatory) (4 bytes)</p>
Mode 1 Physical Layer Configuration Mode	<p>This attribute controls the physical layer configuration to be used in mode 1. The attribute is bit mapped, as follows:</p> <p>Bit 15: DQPSK mode. 0 = "Default Mode", 1 = "Alternate Mode"</p> <p>Bit 14-8: Reserved</p> <p>Bit 7: Randomizer Stage 6 pre-load</p> <p>Bit 6: Randomizer Stage 7 pre-load</p> <p>Bit 5: Randomizer Stage 8 pre-load</p> <p>Bit 4: Randomizer Stage 9 pre-load</p> <p>Bit 3: Randomizer Stage 10 pre-load</p> <p>Bit 2: Randomizer Stage 11 pre-load</p> <p>Bit 1: Randomizer Stage 12 pre-load</p> <p>Bit 0: Randomizer Stage 13 pre-load</p> <p>(R,W) (mandatory) (2 bytes)</p>
Actions	
Get:	Get one or more attributes.
Set:	Set one or more attributes.
Notifications	
Attribute value change:	<p>This notification is used to report autonomous changes of attributes of this managed entity. The notification shall identify its new value. The AVC list is given in Table 2/G.983.2a2.</p>
Alarm:	<p>This notification is used to notify the management system when a failure has been detected or cleared. Both ONT and OLT should know the alarm list used by this entity. The alarm list for this entity is given in Table 3/G.983.2a2.</p>

Table 2/G.983.2a2 – AVC list for Video Return Path Service

Number	Attribute Value Change	Description
1	N/A	
2	OpState	Operational state of VRP Service
3-16	Reserved	Reserved for AVCs of vendor-specific attributes

Table 3/G.983.2a2 – Alarms list for Video Return Path Service

Number	Event	Description
0	Frequency Mismatch	Frequency set by OLT is outside the capabilities of this ONU, or a frequency that is not on the standardized frequency plan
1-255	Reserved	Reserved for vendor-specific alarms

7.2 Video Return Path Statistics

Add the following text to section 7.3.

Relationships

One instance of this managed entity may exist for each ONU. It is created automatically by the ONU on startup, if the ONU implements this service.

Attributes

- Managed Entity id:** This attribute provides a unique number for the instance of this managed entity. This 2-byte number always has the value 0x00. (R) (mandatory) (2 bytes)
- Interval End time:** This attribute identifies the most recently finished 15-minute interval. It is a cyclic counter (modulo 0xFF (256)) that is incremented each time a new interval is finished and the attribute counters are updated. The value of this attribute is 0x00 during the first 15-minute interval that starts with the reception of the "synchronize time" action. The value is 0x01 during the first period after this, and so on. If this managed entity is created after the reception of the "synchronize time" action, the value of this attribute is set equal to the number of the last completed interval. The actual counters of this managed entity start counting directly. The attribute counters are updated at the end of the interval. (R) (mandatory) (1 byte)
- Threshold Data_{B-PON} ID:** This attribute provides a pointer to an instance of the Threshold Data_{B-PON} managed entity that contains the threshold values for the performance monitoring data collected by this managed entity. (R, W) (mandatory) (2 bytes)
- Rx Total bursts:** This attribute reports the total number of bursts detected. (R) (optional) (4 byte)

Rx Good bursts:	This attribute reports the number of bursts that were detected and received correctly. (R) (optional) (4 bytes)
Rx FEC corrected bursts:	This attribute reports the number of bursts that were detected with errors, but which were successfully corrected using FEC. (R) (optional) (4 bytes)
Rx Missed bursts:	This attribute reports the number of bursts that were detected, but that were not received correctly (e.g., errors that are FEC uncorrectable). (R) (optional) (4 bytes)
Rx Min Power:	This attribute reports the lowest power level of all bursts received in the current interval, in units of dBmV. (R) (optional) (1 byte)
Rx Max Power:	This attribute reports the highest power level of all bursts received in the current interval, in units of dBmV. (R) (optional) (1 byte)
Rx Current Power:	This attribute reports the power level of the latest burst received, in units of dBmV. (R) (optional) (1 byte)
Rx FEC corrected Symbols:	This attribute reports the number of symbols that were corrected through the use of FEC. It provides an indicator of the bit error rate of the link. (R) (optional) (4 bytes)

Actions

Set:	Set one Threshold ID.
Get:	Get one or more attributes.
Get current data:	This action returns the current value of one or more actual counters associated with performance monitoring attributes and the value of the Interval End Time attribute representing the interval in which the request is made. The values in the specific counters are reset at the end of the interval. Support of this action is optional. NOTE – "Get" returns the statistical data stored in the attribute values; "Get current data" returns the real-time value of the actual counters associated with those attributes.

Notifications

Threshold Crossing Alert:	This notification is used to notify the management system when a Threshold Crossing Alert (TCA) has been detected or cleared. The TCA change notification "on" will be sent at the crossing of the threshold by the actual counter; the TCA change notification "off" will be sent at the end of the 15 min period since that is when the actual counters are reset to 0x00. The event list for this entity is given in Table 4/G.983.2a2.
----------------------------------	--

Table 4/ G.983.2a2 Video Return Path Statistics

Number	Event	Description	Threshold Data Counter Number *
	Threshold Crossing Alert		
0	Rx Total bursts:	Rx Total bursts threshold crossing	1
1	Rx Good bursts:	Rx Good bursts threshold crossing	2
2	Rx FEC corrected bursts:	Rx FEC corrected bursts threshold crossing	3
3	Rx Missed bursts:	Rx Missed bursts threshold crossing	4
4	Rx Min Power:	Rx Min Power threshold crossing	5
5	Rx Max Power:	Rx Max Power threshold crossing	6
6	Rx Current Power:	Rx Current Power threshold crossing	7
7	Rx FEC corrected Symbols:	Rx FEC corrected Symbols threshold crossing	8
8-255	Reserved		

* This numbering is used with the associated Threshold Data _{B-PON} managed entity. Threshold Data counter 1 indicates the 1st thresholded counter, etc.

8 Managed Entity identifiers

Add the two class values given in Table 5/G.983.2a2 to Table 21/G.983.2.

Table 5/ G.983.2a2 – Managed entity identifiers

Managed entity class value	Managed entity
128	Video Return Path Service Profile
129	Video Return Path Statistics
130..255	Reserved

Add the following Annex A to G.983.2

ANNEX A

Transport of Video Return Path Service

A.1 Network Overview

This recommendation considers networks that use B-PON systems that include a video overlay. This system provides a bidirectional ATM transport service and a unidirectional video or data downstream broadcast or unicast service. If only broadcast video services are desired, then the only video transport required is the third wavelength, as shown in Fig. A.1. The OLT converts the signals on the third wavelength to electrical signals on a coaxial output, suitable for video appliances such as televisions.

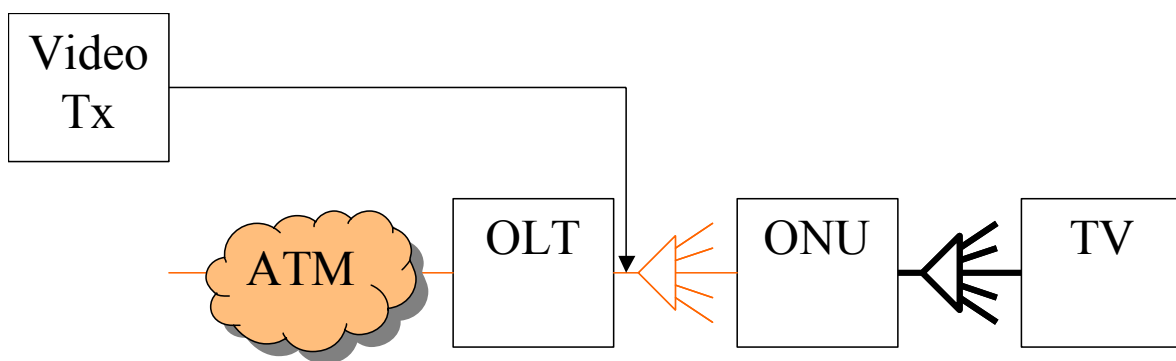

Fig. A.1/G.983.2a2. A B-PON with broadcast video only.

In many cases, however, interactive video services are needed. In this case, the customer's video termination equipment (commonly referred to as a Set Top Box, or STB) needs connectivity back to the video control equipment in the central office. In the case of the B-PON system, this connectivity must be provided by the ONU and OLT. This scenario is depicted in Fig. A.2. The connection begins in the STB, which transmits its information up the coaxial cables that connect it to the OLT. The OLT must receive this information, and adapt it to be carried on the B-PON in the form of an ATM connection. The OLT transports this connection through the network. At some point, the connection then terminates on the video control equipment.

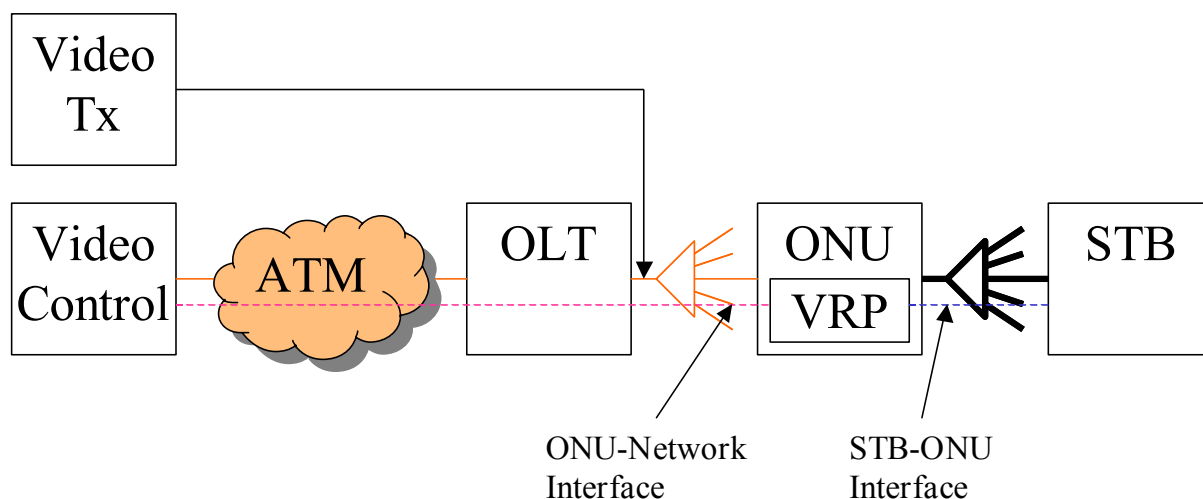

Fig. A.2/G.983.2a2. A B-PON with interactive video services.

Figure A.2 defines two interfaces that are important to interoperability. The STB-ONU interface is the first. This interface is defined by two standards: SCTE 55-1 and SCTE 55-2. These are peer standards that are mutually exclusive; that is, a system will run either one or the other, but not both at one time. Furthermore, each of these standards define several grades of capability, one being chosen as the default (or basic practice). Sections A.2 and A.4 clarify this interface for the purposes of providing the Video Return Path over B-PON.

The second important interface is the ONU-Network interface. This logical interface is an ATM connection that conducts the return path information back to the video equipment in the central office. The information must be formatted in a standardized way so that common control equipment can be used. The formatting depends on the particular return path interface being used. Sections A.3 and A.5 define these formats.

Given the situation that there are two modes on both interfaces, it makes sense that the ONU has two modes of operation, denoted Mode 1 and Mode 2. Mode 1 corresponds to support of the SCTE 55-1 system, and Mode 2 corresponds to support of the SCTE 55-2 systems. The mode is set by the network operator during the initialization management of the video service.

A.2 Mode 1 STB-ONU Interface

The STB-ONU interface in this case is based on that from the commonly deployed SCTE 55-1 standard. The 55-1 standard defines all the aspects of the interactive video control system, while the STB-ONU interface herein described is only concerned with the upstream transmission of data. Therefore, we specify below which sections and sub-sections are relevant to the definition of the STB-ONU interface.

Relevant sections of SCTE 55-1 that apply to the STB-ONU interface:

5.2. PHYSICAL LAYER FOR RETURN-PATH TRANSMISSION

5.2.1. Return-Path Modem Description – A general explanation, Required.

5.2.2. RF Return Path Packet Format – Specifies the format of the upstream packet, Required.

Please note that the unique word specified in this section is given in standard QPSK notation, and not differential QPSK notation.

5.2.3. RF Return-Path Forward Error Correction – Specifies the code used for the FEC bytes, Optional.

Please note that while the FEC will be calculated by compliant STBs, the ONT's processing of the FEC is optional.

5.2.4. RF Return-Path Randomizer – Specifies the randomizer used in the upstream packets, Required.

Please note that the randomizer output is applied to the entire packet EXCEPT the unique word. Also, the programmable value of the randomizer seed to be used is given in the Video Return Path Service Profile Managed Entity.

5.2.5. RF Return Path Modulator – Specifies the physical layer to be used, Required.

Note that while the center frequency is specified to a wider range, in actual practice this frequency is limited from 8 to 12 MHz. Also, the DQPSK mode to be used is given in the Video Return Path Service Profile Managed Entity.

5.2.6. RF Return-Path Demodulator Specification – Specifies the physical layer to be used, Required.

All other sections of SCTE 55-1 are not relevant to the STB-ONT interface. In particular, the extended practice (section 5.3) is explicitly not supported.

A.3 Mode 1 ONU-Network Interface

In mode 1, the ONU must forward the de-randomized packet sequence field (1 byte) and the ATM data (53 bytes) intact to the video control system. The procedure to do this is:

1. Receive the DQPSK burst, and capture all 62 bytes of data and measure the power level of the burst relative to the nominal input power level for the receiver.
2. Exclusive OR the randomizer sequence with the received data.
3. (Optional) Calculate the FEC parity, compare with that received, and detect/correct errors. Discard cells that have uncorrectable errors.
4. Assemble the datagram to be forwarded, which is 56 bytes in length.
5. Encapsulate the datagram using AAL5.
6. Forward the AAL5 segments over an ATM Virtual Circuit allocated on the PON.

The structure of the incoming RF burst data and the outgoing ATM circuit data is shown in Fig. A.3. The outgoing datagram is always 56 bytes in length, and is composed of a two byte Level Indication field, a one byte packet sequence field, and a 53 byte ATM data field. The unique word and FEC bytes are terminated in the ONU.

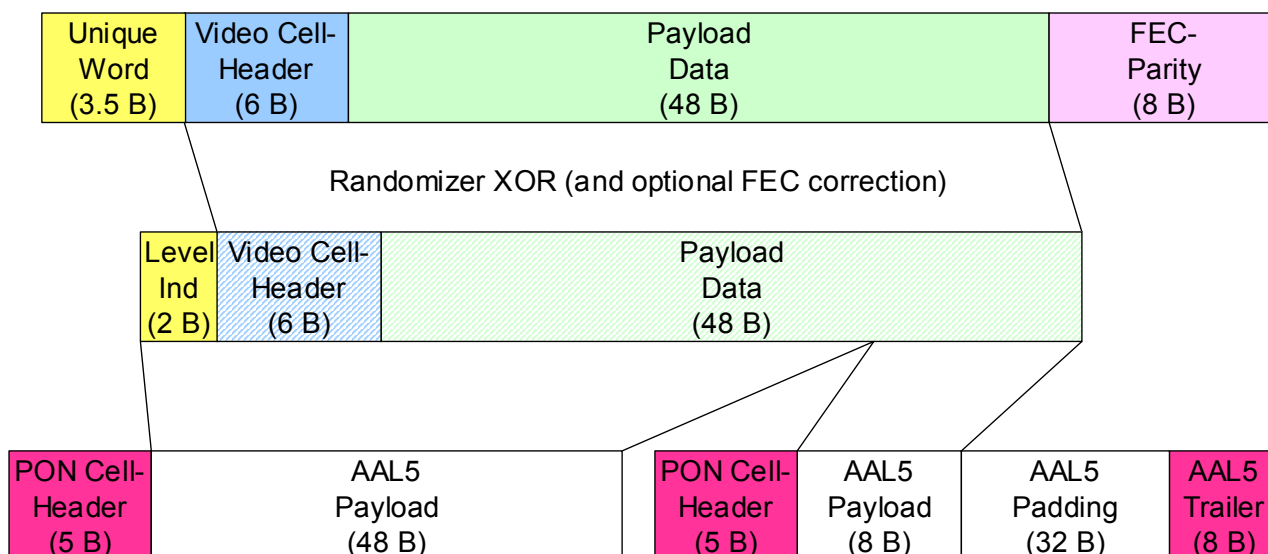

Fig. A.3/G.983.2a2. The transformation of a 55-1 formatted burst into ATM datagrams.

The level indication field is formatted as: a1bb bbbb 0000 0000, where

The bit ‘a’ is a detection indicator to be used if FEC is implemented in the ONT (if not, bit ‘a’ should be set to zero always), where:

a=0 means burst was detected without errors;

a=1 means a burst was detected with errors, but was corrected

The ‘1’ is a reserved bit.

The bits ‘bbbbbb’ are a power indication, containing the 2’s complement representation of the measured power of this burst, in units of decibels relative to the nominal receive power of the equipment. For example, if the nominal receive power of the ONU is 10 dBmV, and a burst arrives with 17 dBmV, then bbbbbb=000111. If the same ONU receives a 7 dBmV burst, then bbbbbb=111101.

The “0000 0000” are all reserved bits.

The ATM VC that carries the video return path data can be configured to provide a UBR service. The cell rate of the service can be calculated from the latency requirements of the 55-1 protocol and equipment implementation. Practical implementations of this protocol have round trip delay tolerances on the order of 100 ms. After this time, the STB will begin to re-transmit its upstream cells. One of the contributors of the delay will be the cell transmission time, which in our case is double the inverse cell rate.

For example, if 20 ms is allocated for cell transmission time, then the cell rate for the video return path connection should be made $2/20\text{ms} = 100$ cps.

To summarize, the ONU-Network interface is 56 byte payloads (as defined above) encapsulated in AAL5, carried in an ATM VC.

A.4 Mode 2 STB-ONU Interface

The STB-ONU interface in this case is based on that from the commonly deployed SCTE 55-2 standard. The 55-2 standard defines all the aspects of the interactive video control system, while the STB-ONU interface herein described is only concerned with the upstream transmission of data.

Therefore, we specify below which sections and sub-sections are relevant to the definition of the STB-ONU interface.

Relevant sections of SCTE 55-2 that apply to the STB-ONU interface:

2.2 Upstream Physical Interface Specification – A general explanation of the system, Required.

2.2.1 Quaternary Phase Shift Keying (QPSK) – A description of the physical layer used, Required.

Grade A 256 Kbps is optional

Grade B 1.544 Mbps is required

Grade C 3.088 Mbps is optional

2.2.2 Coaxial Cable Impedance – A physical layer parameter, Required.

2.2.3 Time Division Multiple Access (TDMA), Optional.

2.2.4 Contention Based Access, Required.

All other sections of SCTE 55-2 are not relevant to the STB-ONT interface.

A.5 Mode 2 ONU-Network Interface

In mode 2, the ONU forwards the de-randomized and re-addressed ATM cells (53 bytes) to the video control system. The procedure to do this is:

1. Receive the QPSK burst, and capture all 59 bytes of data.
2. Exclusive OR the randomizer sequence with the received data.
3. (Required) Calculate the FEC parity, compare with that received, and detect/correct errors. Discard cells that have uncorrectable errors.
4. Perform a virtual circuit merge on all connections coming from the subtending STBs. Note that this merging function requires the ONU to queue all cells in a subtending VC until the end-of-packet indication is received. This maintains AAL5 user payload frame delineation.
5. Forward the merged AAL5 segments over an ATM Virtual Circuit allocated on the PON.

The structure of the incoming RF burst data and the outgoing ATM circuit data is shown in Fig. A.4. The outgoing datagram is a 53-byte ATM cell. The cells have undergone a VC merge. The unique word and FEC bytes are terminated in the ONU.

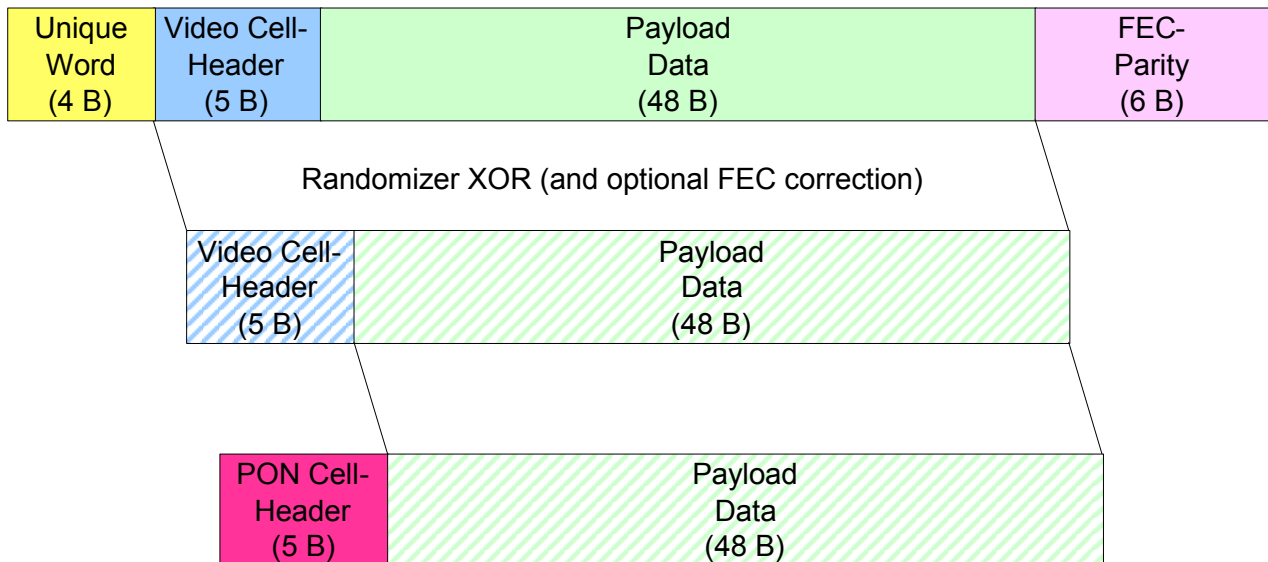

Fig. A.4/G.983.2a2. The transformation of a 55-2 formatted burst into ATM datagrams.

The ATM VC that carries the video return path data can be configured to support the operator chosen QoS.

This method provides efficient bandwidth usage upstream since it maps the ATM payload from the STB onto the PON directly on a PON allocated VC.

To summarize, the ONU-Network interface is 53 byte cells, carrying AAL5 encapsulated data, using a PON allocated ATM VC.

Add the following appendix to G.983.2

APPENDIX VII

Transparent support of Video Return Path Service

The following network configurations are examples of various interworking methods that do not employ the OMCI and transport methods described above.

I.1 Network Overview

This section considers support of the video return path. The following configurations are presented:

Configuration 1:

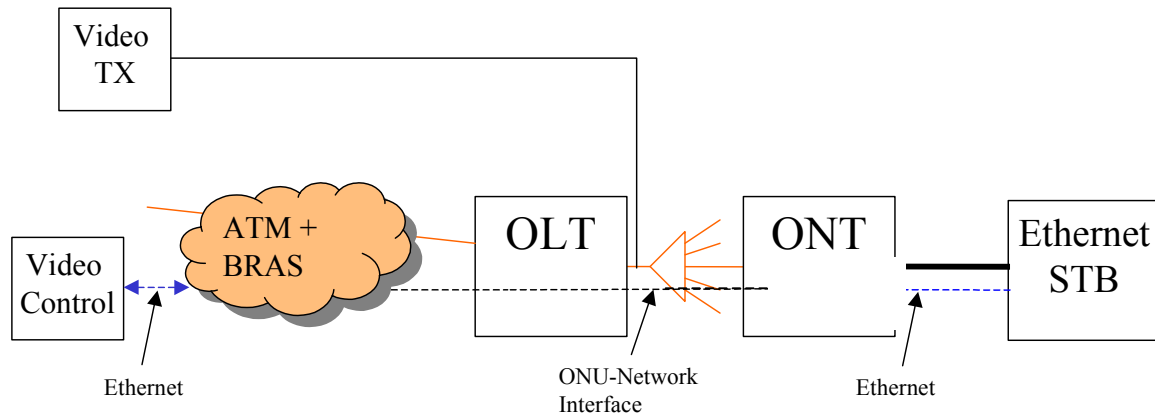

Fig. I.1/G.983.2a2. A B-PON with ONT transparent support of interactive video services.

In this type of configuration, the STB is Ethernet capable and can perform the TCP/IP protocols to configure itself and exchange information between the STB and the video control system.

The ONT transparently bridges the STB data to a BRAS which terminates the ATM layer and forwards the extracted Ethernet packets to the video control system.

This configuration requires no new B-PON Recommendation.

Configuration 2:

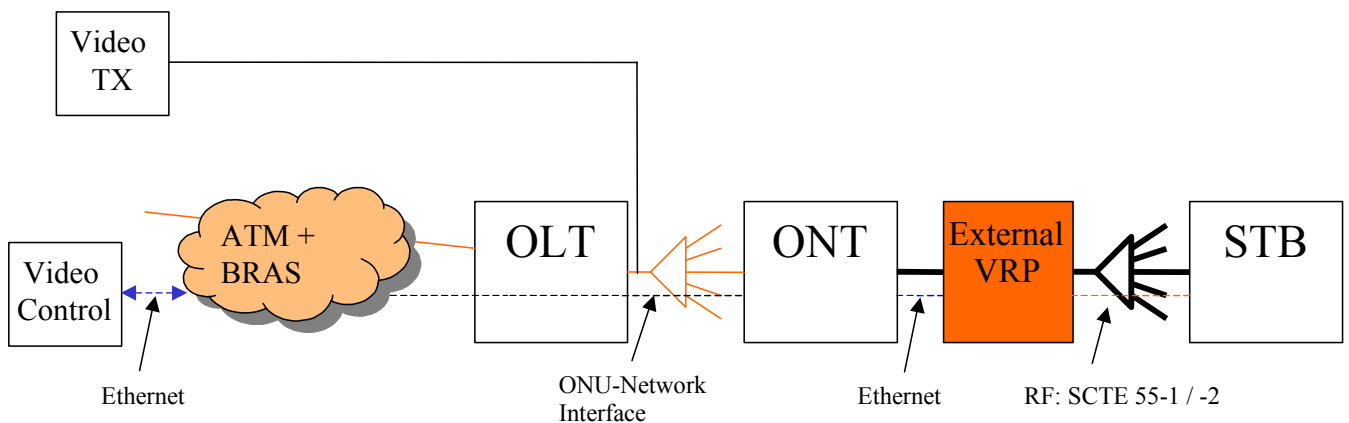

Fig. I.2/G.983.2a2. A B-PON interactive video services with external VRP adaptation.

In this configuration, the STB is compliant with SCTE 55-1/-2 and interfaces to an external VRP device that terminates the RF and performs the adaptation function from RF to Ethernet.

The interface between the ONT and the VRP device is Ethernet.

The ONT transparently bridges the STB data to a BRAS which terminates the ATM layer and forwards the extracted Ethernet packets to the video control system.

This configuration does not require new B-PON Recommendation.

Configuration 3:

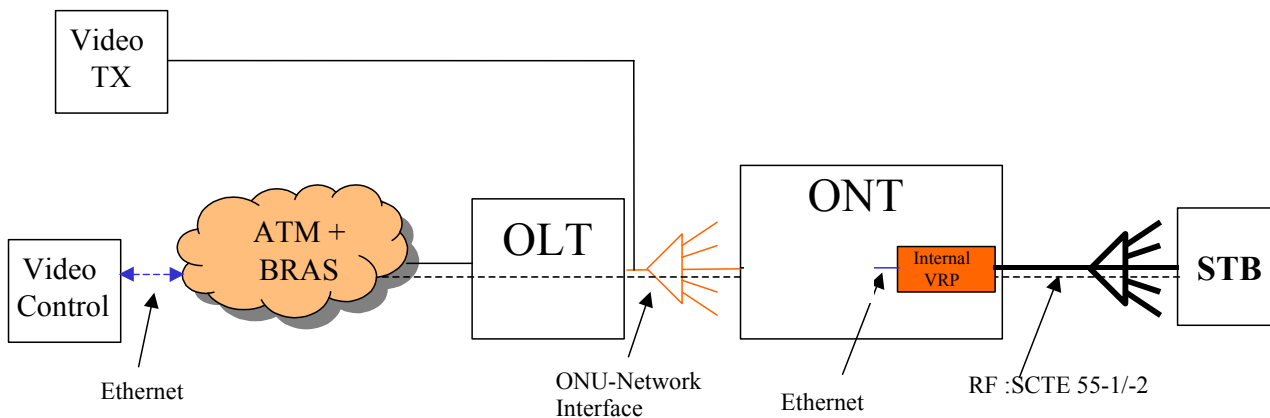

Fig. I.3/G.983.2a2. A B-PON interactive video services with internal VRP adaptation.

In this configuration, the STB is compliant with SCTE 55-1/-2 and interfaces to an internal VRP device that terminates the RF and performs the adaptation function from RF to Ethernet for input to the 802.1 D bridge in the ONT.

The ONT transparently bridges the STB data to a BRAS which terminates the ATM layer and forwards the extracted Ethernet packets to the video control system.

This configuration does not require new B-PON Recommendation.